

Tectonic Structure of the Island of Hvar (Southern Croatia)

Stanko MARINČIĆ

Key words: Kinematics of deformation, Tectonic phases, Island of Hvar, Croatia.

Ključne riječi: kinematika deformacija, tektonske faze, otok Hvar, Hrvatska.

Abstract

Structural deformation of the island of Hvar allows three tangential tectonic phases to be determined: the Laramian (F I), the Pyrenean (F II) and the Neotectonic phase (F III). Preserved relics of Laramian and Pyrenean folds with intact structural elements, indicates that the Neotectonic orientation of structures (E-W) is a consequence of refolding of the older structural fabric, rather than horizontal rotation.

Sažetak

Na temelju svojstava strukturnih deformacija otoka Hvara determinirane su tri tangencijalne tektonske faze: laramijska, pirenejska i neotektonska faza koje su uvjetno označene kao F I, F II i F III. Sačuvani relikti laramijskih i pirenejskih bora s intaktnim strukturnim elementima, ukazuju da neotektonska orijentacija struktura istok-zapad nije posljedica horizontalne rotacije već preobaranja starijeg strukturnog sklopa.

1. INTRODUCTION

Geological development of the island of Hvar from the Neocomian to the Eocene-Oligocene (Fig. 1) indicates several phases of tectonically induced changes. Emersion of Aptian and Albian deposits is a regionally widespread example of such tendencies, but the cause is indeterminated. At the end of the Upper Cretaceous, during a relatively short interruption in platform carbonate deposition, more important structural deformation occurred. These were attributed to the so-called Laramian tectonic phase. Similarly, the effects of the Lutetian-Oligocene Pyrenean tangential phase, as well as the effects of the Neogene-Quaternary Neotectonic tangential phase were determined.

This nomenclature has been kept because of its historical establishment in the Croatian geological literature. The Laramian phase, as the oldest tectonic deformation, will be referred to as F I, the Pyrenean phase as F II, and the youngest Neotectonic phase as F III.

2. KINEMATICS OF DEFORMATION AND TECTONIC PHASES

The most obvious influences of the tangential tectonic phase on the sedimentary system are expressed by shorter or longer periods of non-deposition during the emersion phases, or by essential changes recorded in the large sedimentary systems (e.g. succession from platform carbonates to flysch to molasse). Such phases

were recorded as events during certain periods of the geological time. However, it is incorrect to undoubtedly connect each sedimentary gap with tectonics, until a clear tectonic cause has been determined. Without such clear tectonic evidence sedimentological changes should be regarded on the level of recognition of the characteristic facies.

Under the tangential stress, as a result of the kinematic conditions, the longer axis (b-axis) of the deformational fabric is oriented normal to the stress. Therefore, the b-axis of the fold, as a product of optimal deformation, is also oriented normal to the stress. Complete fold geometry, including all deformational sets (limbs, amplitude, span, index, b-axis, vergence, joint sets, etc.) represents the kinematic record of a given stress orientation. In practice, under stress of any orientation, the development of the deformation will result in stepwise changes, which could be defined as kinematic stages. From this point of view, kinematic stages represent a general paradigm, which will be explained using the example of the Neotectonic structural fabric of the island of Hvar.

A very important factor for each geological body is its spatial position during the geological processes. Consequently, the most important factor for its deformational fabric is its structural orientation. Both aspects are controlled by geological time. Therefore, the primary deformations directly indicate the orientation of the regional stress during the specific tangential tectonic phase.

The influence of the Laramian tectonic phase (F I) is indicated by the emersion at the end of the Upper Cretaceous, and sporadic relics of metre- to decametre-scale folds. These folds with a N-S b-axis strike, and corresponding joint sets, could have been formed only under

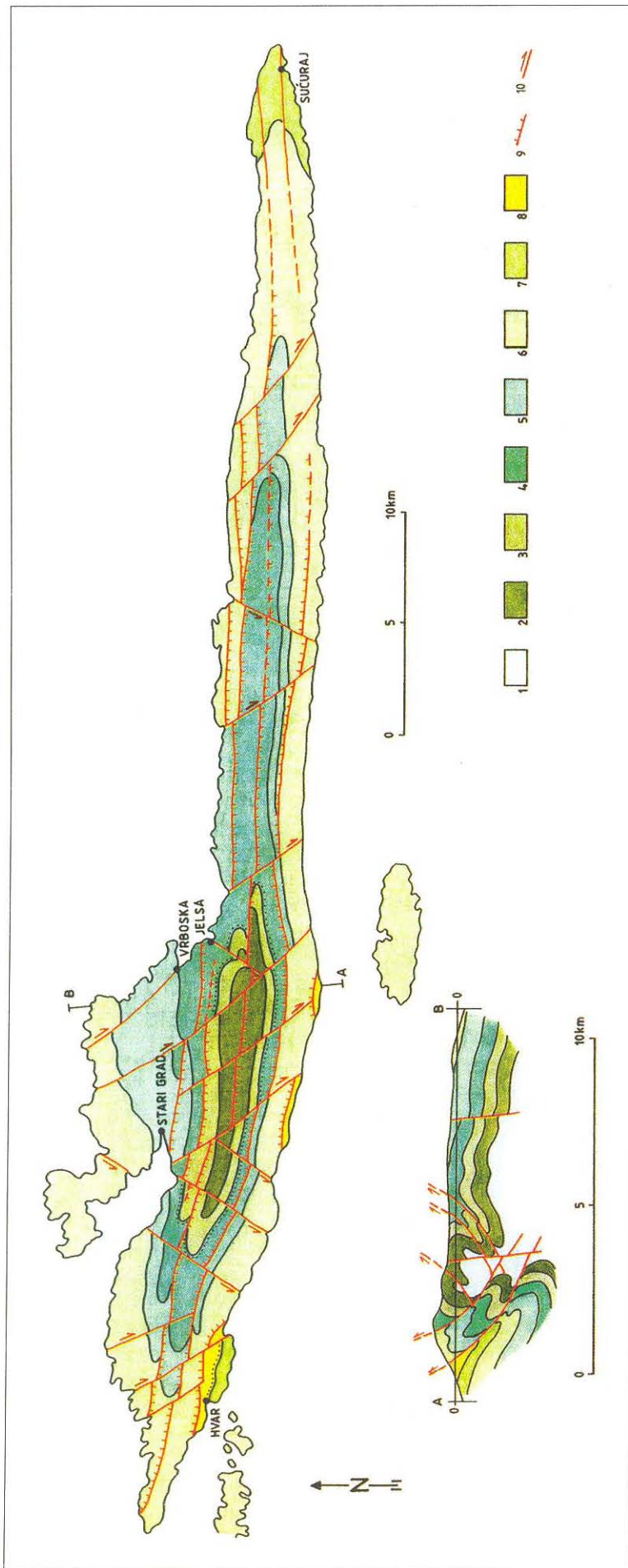

Fig. 1 Schematic geological map of the island of Hvar. Legend: 1 - Malmian deposits (simplified); 2 - Neocomian platform deposits (dolomites with micrite lenses); 3 - Barremian-Aptian platform carbonates (rhythmic alternation of micrites and bioclastic limestones with dasycladaceans); 4 - Albian-Cenomanian platform carbonates (cryptalgal laminites and late-diagenetic dolomites); 5 - Cenomanian platform carbonates (cryptalgal limestones containing fossil fish and reptiles, rudist biostromes); 6 - Turonian-Santonian platform carbonates (micrites, oncoidal, cryptalgal and rudist limestones); 7 - Campanian-Maastrichtian platform carbonates (homogenous micrites); 8 - Palaeogene flysch; 9 - reverse fault; 10 - strike-slip fault.

Sl. 1 Pregledna geološka karta otoka Hvara. Tumač: 1 - malmske naslage (pretpostavljeno); 2 - neokomski platformni karbonati (dolomiti s lećama mikritnog vapnenca); 3 - barem-aptski platformni karbonati (ritmička izmjena mikritnih i bioklastičnih vapnenaca s dazikladacejama); 4 - albsko-cenomanski platformni karbonati (kriptalgalni vapnenici i kasnodijagenetski dolomiti); 5 - cenomanski platformni karbonati (kriptalgalni vapnenici s fosilnim ribama i gmazovima, rudistne biostrome); 6 - turon-santonski platformni karbonati (mikritni, onkoidni, kriptalgalni i rudistni vapnenici); 7 - kampan-mastrihtski platformni karbonati (homogeni mikritni vapnenici); 8 - paleogenski fliš; 9 - reverzni rasjed (čelo ljuške); 10 - rasjed s horizontalnim kretanjem.

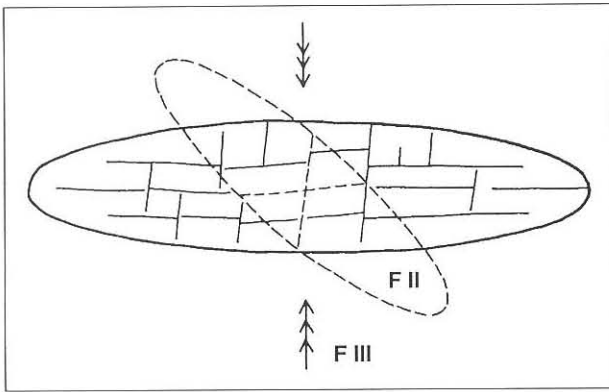

Fig. 2. Neotectonic compression (F III) reactivating first generation of h01 joints of the Pyrenean phase (F II) into tensional joints and axial plane joints.

Sl. 2. Neotektonska kompresija (FIII) reaktivira prvu generaciju h01 pukotina pirenejske faze (FII) u tenzijske pukotine i pukotine osne ravnine.

the influence of the E-W oriented regional stress, i.e. during the Laramian tectonic phase.

Relics of the Laramian folds preserved their recognizable geometries although they were refolded during later Pyrenean and Neotectonic phases. They were incorporated in the limbs of the Neotectonic folds, changing only the inclination of their B-axis (traces of the axial planes of the Laramian folds are parallel to the "a-lineations" in the limbs of the Neotectonic folds).

Under the influence of the Pyrenean tangential tectonic phase during the Middle Eocene, a trough filled with flysch was formed within the former carbonate platform (MARINČIĆ, 1981). This event marked the commencement of the disintegration of the former Mesozoic carbonate platform. Syntectonic sedimentation of the Eocene-Oligocene flysch deposits was, under the influence of the SW-NE oriented Pyrenean stress, accompanied by the subduction of the Adriatic platform beneath the Dinarides. The Dinarides were folded, forming the famous structural phenomena, known as "the Dinaric strike" or "the Dinaric structures". These structures are characterized by their NW-SE strike and SW vergence.

On the island of Hvar, Pyrenean folds are only sporadically preserved. Due to their originally diagonal orientation (Fig. 2) they were unable to provide strong resistance to the neotectonic stress. Therefore, the only preserved parts of the Pyrenean folds are those which were in a favourable position to become incorporated into the limbs of the Neotectonic folds. These Pyrenean folds have only changed the original inclination of their b-axis; they also sporadically preserved their Pyrenean SW vergence. The Neotectonic stress efficiently accepted each Pyrenean fracture which could have been incorporated into its own deformational set. The left sliding joints of the first Pyrenean h01 generation joint sets formed joints of the axial plane, and the right ones formed tensional joints of the Neotectonic folds (Fig. 2).

Although the relics of Laramian and Pyrenean folds are not so frequent as the predominant Neotectonic

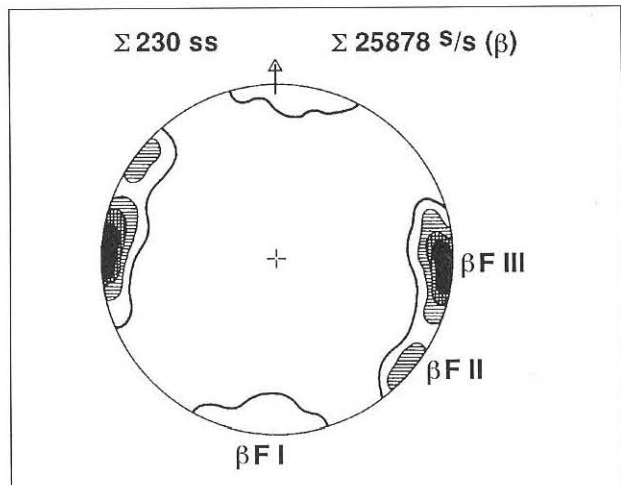

Fig. 3. Synoptic β -diagram of the island of Hvar.

Sl. 3. Sinoptički β -dijagram otoka Hvara.

folds, their presence is very important (Fig. 3). Under the influence of the Neotectonic stress they have only changed the inclination of their b-axis, but they preserved the original orientation. Therefore, their mutual arrangement is rather well preserved (Fig. 4). It must be noted that their original structural fabric was only refolded during the activity of the Neotectonic stress oriented N-S. Therefore, it was not horizontally "counter-clockwise rotated" around the tectonic c-axis, which has recently become the usual explanation for each occurrence of "the Hvar strike" in the Dinarides (e.g. ALJINOVIĆ et al., 1990). Only a rootless nappe could horizontally rotate, and the Hvar thrust-sheet or thrust-sheets are definitely not examples of these rootless structures. Some locally observed horizontal rotations along the strike-slip faults (h01) are of the outcrop-scale. Even the remarkable sum of their differential left movements cannot contribute to the predominance of one direction over the other (i.e. rotation), since it is compensated by movements along the right strike-slip faults. Besides, these movements are included into the deformations of the kinematic F-stage (the fourth h01 generation), which took place after the formation of "the Hvar strike". Finally, at the frontal surfaces of the thrust-sheets with south vergence all tectoglyphs are oriented perpendicularly - they are not oblique, neither do they generally indicate any aberration from the North-South direction.

With the appearance of a new global stress oriented North-South, a new Neogene-Quaternary Neotectonic tangential phase (F III) began. Intensified subduction continued, resulting in the disintegration of the Adriatic Carbonate Platform in several parts (ALJINOVIĆ et al., 1987). At the same time in the area of the Dinarides structural deformations of East-West strike ("the Hvar strike") and South vergence were formed.

The specific geological development and geotectonic position of SW Istria and the islands of Lastovo and probably Vis, indicate that they represent relics of the Adriatic Carbonate Platform. Therefore, the island of

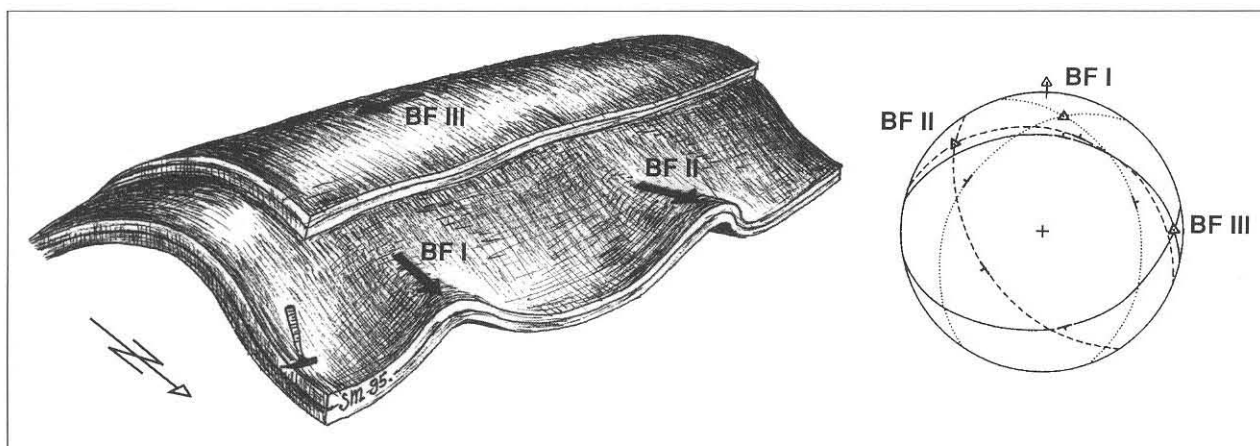

Fig. 4 Relics of Laramian (F I) and Pyrenean (F II) folds in limbs of the Neotectonic fold (F III) near Vrboska.

Sl. 4 Relikti laramijskih (F I) i pirenejskih (F II) bora u krilu neotektonske bore (F III); Vrboska.

Hvar represents a considerably protruded part of the great structural complex of the Dinarides in the vicinity of the Neotectonic subduction zone. Consequently, it underwent stronger contraction, which resulted in remarkable deformation during the Neotectonic tangential tectonic phase.

Although the direction of the stress is of primary importance for the determination of the tectonic phase and understanding of the geological development of a certain area, it is not so substantial from the kinematic point of view. The ideal kinematic sequence of deformation is identical under any stress orientation. Therefore, the Neotectonic deformation of the island of Hvar could be treated as a general example. Kinematic changes are designated as six stages of kinematic development: A, B, C, D, E and F (Fig. 5). They are defined on the criteria of the successive appearance of the important tangential deformational sets.

The first reaction to compression is expressed by a tension parallel to the plane of the greatest and the intermediate principal stress ($\sigma_1 - \sigma_2$), resulting in the opening of tensional gaping joints of the A-stage. These joints are small (centimetre to decimetre scale), and usually they do not cut the entire thickness of a bed.

They are very expressive due to their feather-like shape filled with white sparitic calcite. They are present only in the parts of the $\sigma_1 - \sigma_2$ plane with the minimal difference between resistance and tangential pressure (in limestones approximately 38° towards the direction of the main stress).

During stage B the h0l zone was torn, with characteristic sliding along the conjugated h0l joint sets (the first h0l generation). Joints are of the centimetre to metre scale, usually cutting through the entire bed, but they do not disturb other beds, since they terminate at the interbed discontinuity. Their dimensions are controlled by the thickness of the bed, and, therefore, they cannot evolve into faults. Commonly they are characterised by small-scale left or right movements with small tectoglyphs parallel to the bedding. These small-scale movements also interrupt tensional joints of the A stage, which preceded them. Unfortunately, this described succession of events is often misinterpreted; as tensional joints are interpreted as being of secondary origin (as a consequence of moving along the sliding h0l joints).

The A and B stages represent a period of compensation of the main stress on the level of a single bed. The

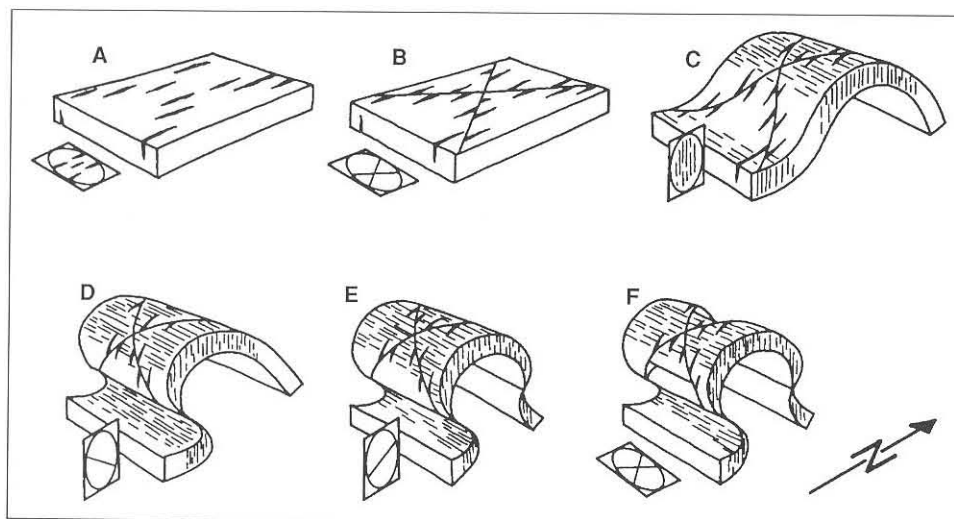

Fig. 5 Kinematic stages of deformation development in the example of Neotectonic compression.

Sl. 5 Kinematski stadiji razvoja deformacija na primjeru neotektonske kompresije (F III).

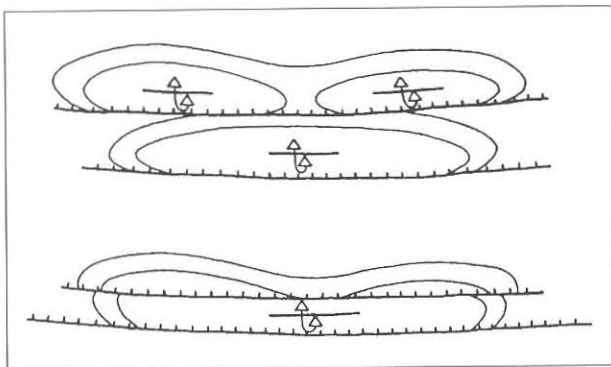

Fig. 6 Integration of thrust-sheets into a kinematically more resistant larger thrust-sheet.

Sl. 6 Integriranje ljusaka u kinematski otporniju veću ljusku.

continuation of stress leads to the substitution of the already exhausted small-scale resistance with a group of beds. From this stage on, the resisting complex is striving for homogenization, which in this way leads to the large-scale deformations. During the resistance to the material disintegration, a homogeneous group of beds is facing by its wider front towards the main stress. This leads to the redistribution of the intermediate and the least principle stress (σ_2 and σ_3), resulting with the most efficient consequence: bending of beds and folding. The folding is accompanied by the additional compensation of stress in the form of release along the compression cleavage of the axial plane.

The C stage is characterised by the complete change of geological relations, since the most important contractional change resulted in tectonic transport parallel with the least principal stress - σ_3 . Sedimentation ceased or is continued under different conditions at a different location. During stage C of the Laramian tectonic phase wide areas were uplifted and emerged (not only the area of the former carbonate platform), while during the C stage of the Pyrenean phase there was a shift from the shallow-water carbonate sedimentation to the deposition of flysch. The same kinematic stage during the Neotectonic phase resulted in the final orogeny.

Advancing deformation leads to the increase of the fold compression index, and a higher inclination of the characteristic southern vergence of the Neotectonic contraction. The only remaining resistance to the main stress is represented by the ductility of the fold material. Overcoming the ductility during the stage D leads to the releasing of folds, and their breaking along the zone of the least difference between the resistance and the tangential stress. This zone is represented by the sliding set of the second h01 generation. In concordance with the large structural forms, kilometer-scale h01 sets of reverse faults with perpendicular (N-S) decimetre to metre-scale tectoglyphs, were formed. The most impressive consequence of the Neotectonic contraction of the island of Hvar was the formation of the thrust-sheets from the former folds, with southern vergence ("the Hvar strike").

Thrust-sheets, instead of "the single island thrust-sheet" as usually quoted in the literature, therefore represent the structural essence of the island of Hvar. So far established opinions on only one thrust-sheet were probably based on a very remarkable contact of the front of the southernmost thrust-sheet with flysch, and the apparently continuous succession between the core and the younger deposits. However, it should be noted that the flysch represents only the youngest deposits in the succession, not a continuous surface used for thrust-sheet motion. By the nature of deformation of the wider structural fabric, it is only possible to conclude that this southernmost thrust-sheet represents the first, i.e. the oldest thrust-sheet structure. Towards the North successively younger thrust-sheets of the Neotectonic stage D could be found. Moreover, opinions on only one thrust-sheet structure imply that stage C consisted of a single, huge fold, which had reworked the entire older Pyrenean structural fabric (also supposed to be composed of a single, huge fold). Existing relics of older, Pre-Neotectonic folds, indicate that this was definitely not the case. The Neotectonic stage C formed so many en échelon folds because it first refolded the majority of the older structures, and then included them into the thrust-sheet structures. The cause for the apparent integral core of the island (or apparent single island thrust-sheet) could probably have been a very persistent and strong Neotectonic compression, resulting in contraction of folds and formation of thrust-sheets, as well as in the integration of tectonically reduced cores into the new, secondary core, and reduced frontal parts of folds into the new, secondary front (Fig. 6). The kinematic succession from one stage to the other, therefore, represents substitution of already "consumed" structural forms with the more resistant ones. Successively, "consumed" elements were integrated into a large resistant structure, acting like a single thrust-sheet in contact with flysch.

The kinematic stage E represents an even more characteristic feature of the island of Hvar than its strike. Although the local occurrences of the deformations of this stage were found all over the Dinarides, on the island of Hvar they are an inevitable feature of the complete Neotectonic structural fabric, down to outcrop level. These deformations are partly the result of the specific regional geotectonic position of the island (as a protruded segment of the Neotectonic overthrusting of the Dinarides on the Adriatic platform), but they are also a consequence of the internal structural fabric of the island of Hvar. Numerous reduced thrust-sheets, composing the apparent integral structure of the island, have under the intensified strain begun to respond autonomously to the stress. Each thrust-sheet, from the smallest to the largest, was released along the new deformational set of h01 joints and faults of the kinematic stage E. This third generation of h01 reverse faults, together with earlier h01 reverse faults of stage D, formed a conjugated h01 set. This resulted in the conjugation of thrust-sheets of all scales, and complete

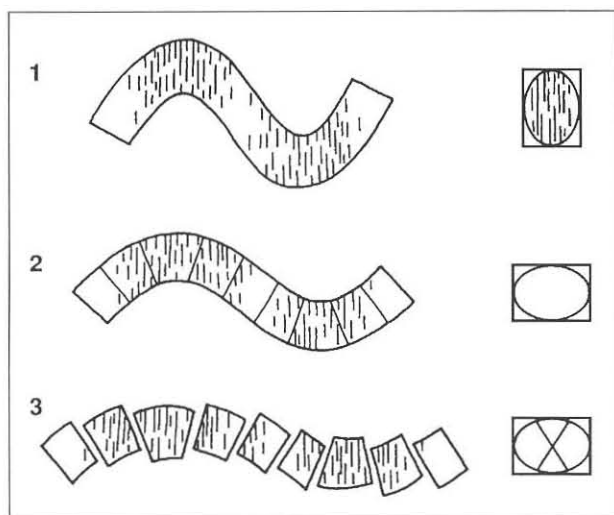

Fig. 7 The sequence of deformation from contraction (1) to extension (2) and gravitational joints (3).

Sl. 7 Slijed deformiranja od kontrakcije (1.) do ekstenzije (2.) i gravitacijskih h01 pukotina (3.).

conjugation of the integrated thrust-sheet of the island of Hvar. Towards the south folds and thrust-sheets are of southern vergence, and towards the north they are of the northern vergence. The tangential stress was consumed in both directions of the reverse movements, in this way increasing the tectonical transport along the axis of the least principle stress (σ_3). Hinges of the structures were in the position of the decreased lateral pressure, resulting with the opening of the older disjunctive sets of the A, B and C stages.

The kinematic stage F comprises the youngest set of the Neotectonic tangential deformations on the island of Hvar. The global stress already overcame the resistance of the folds and thrust-sheets as deformation of stage E proceeded. In this way, stage F could be compared with stage B, but of a higher deformational level: it is characterised by the reactivation of the stage B first generation of h01 fault sets. The F stage represents, therefore, the fourth h01 generation, characterised by the intensive horizontal movements along the left and right strike-slip faults, usually cutting all parts of the Hvar structural fabric (Fig. 1). It comprises large-scale faults with limonitized surfaces and decimetre-scale subhorizontal tectoglyphs.

In a complex structural fabric, like that of the island of Hvar, kinematic stages follow each other according to the structural maturity of each structural segment. Therefore, due to the progression of the Neotectonic stress towards the south, each zone is practically in a different kinematic stage at the same time.

The question of the influence of extensional phases and extension was omitted in the above analysis. Their influence is much more predictable than that of contractional phases, because they certainly follow after each contractional phase.

Folded deposits, when exempt from the tangential stress and stimulated by the regional widening, aimed to reestablish their primary form due to their preserved elasticity. However, soon they exceed their elasticity limit, resulting in the formation of the extensional joints in the zone of the b-axis. Since tangential stress was subsequently completely substituted by the gravitational force, extensional joints in the zone of the b-axis were reactivated into the gravitational h01 set of conjugated sliding joints (Fig. 7). Along these joint sets antiforms ascended and synforms descended, similar to the isostatic movements.

Without this cyclic succession of the tangential and radial tectonic movements, the reestablishment of sedimentation at the same locality would not be possible. During the extensional phase the uplifted mountain ranges were flattened, and the erosion was lowered enough for deposition to become reestablished. Thus, on the island of Hvar the Aptian emergence was succeeded by the Upper Albian immersion, the Albian emergence by the Cenomanian immersion, etc.

The next tangential phase appeared only when the velocity of the horizontal movement of the African plate increased enough to dominate the rotational velocity. Along a new vector of total movement a new compression of the global stress was generated, being recognised as the new tectonic tangential phase.

3. REFERENCES

- ALJINOVIĆ, B., PRELOGOVIĆ, E. & SKOKO, D. (1987): Novi podaci o dubinsko-geološkoj građi i seizmotektonski aktivnim zonama u Jugoslaviji.- *Geol. vjesnik*, 40, 255-263.
- ALJINOVIĆ, B., PRELOGOVIĆ, E. & SKOKO, D. (1990): Tectonic processes and the contact of the Adriatic platform and Dinarides in the area of the northern Dalmatia.- *Proc. of the Int. Conf. on mechanics of jointed and faulted rocks*, 179-182, A.A. Balkema, Rotherdam-Brookfield.
- MARINČIĆ, S. (1981): Eocenski fliš Jadranskog pojasa.- *Geol. vjesnik*, 34, 27-38.

Tektonska struktura otoka Hvara

Stanko MARINČIĆ

1. UVOD

Razvoj geoloških naslaga otoka Hvara, od neokoma do eocen-oligocena (Sl. 1), svjedoči da je ovo područje u više navrata pretrpjelo promjene izazvane tektonskim pokretima. Dobro su npr. izražene emerzije aptskih i albskih naslaga slično kao i širom krških Dinarida, ali ni u jednom ni u drugom slučaju ove pojave nisu i specifički determinirane. Za sada nisu prepoznati bilo kakvi relevantni pokazatelji o tipu strukturnih deformacija prema kojima bi se moglo zaključiti o tektonskoj naravi ovih emerzija i njihovoj uzročnoj vezi s određenim tektonskim fazama. Tek su na kraju gornje krede, za relativno kratkotrajnog prekida sedimentacije platformnih karbonata, u dovoljnoj mjeri izražene strukturne deformacije svojstvene tzv. laramijskoj tangencijalnoj tektonskoj fazi. Analognim je postupkom još determiniran učinak djelovanja lutet-oligocenske tzv. pirenejske tangencijalne faze i neogensko-kvartarne neotektonske tangencijalne faze.

Ovakvo nazivlje tektonskih faza je zadržano zbog njihove povijesne ukorjenjenosti i prepoznatljivosti u našoj geološkoj literaturi, pa i zato što ne postoji neko drugo. Budući da su najstariji definirani tektonski pokreti ovog područja laramijski, oni su uvjetno označeni kao prva tektonska faza - F I, pirenejska kao F II i neotektonska faza kao F III.

2. KINEMATIKA DEFORMIRANJA I TEKTONSKE FAZE

Najuočljivija posljedica djelovanja tangencijalne tektonske faze na sedimentacijski sustav je duži ili kraći prekid sedimentacije (emerzija) ili pak, bitne izmjene velikih taložnih sustava (platformni karbonati - fliš - molasa). Po tome se zapažaju kao događaji u određenom geološkom vremenu. Međutim, ne može se baš za svaki prekid u sedimentaciji *a priori* tvrditi da je izazvan tektonikom dok se ne dokažu tektonski ili ini uzroci. Bez utvrđenih uzroka, sedimentacijske promjene ostaju samo na rangu konstatacije prepoznatog facijesa.

Pod tangencijalnim stresom, silom kinematskih uvjeta duža os (b-os) deformacijskog sklopa je u položaju normale na stres. Također i bora, kao optimalna referentna deformacija sklopa, ima B-os normalnu na stres. Sva geometrija bore i svi pripadajući joj deformacijski sustavi (krila, amplituda, raspon, indeks, B-os, vergencija, pukotine itd.) kinematski su iskazi orijentiranog stresa. Praktički, pod stresom bilo koje orijentacije, deformiranje napreduje identičnim kinematskim tijekom koji se manifestira u kinematskim skokovima kao rang stanja deformacije ili kinematski stadij. U toj su mjeri kinematski stadiji opći obrazac koji će se pobliže obrazložiti na primjeru neotektonskog strukturnog sklopa otoka Hvara.

Koliko je za neko geološko tijelo od presudne važnosti prostorna lokacija, toliko je za njegov deformacijski sklop

prostorna orijentacija. Dakako, oba su aspekta kontrolirana geološkim vremenom i baš zbog toga će autentične primarne deformacije neposredno svjedočiti o pravcu regionalnog stresa kao o prepoznatljivoj tangencijalnoj tektonskoj fazi.

Prisutnost učinka laramijske faze - F I, osim emerzije koncem gornje krede, indiciraju mjestimični relikti relativno velikih, metarskih do dekametarskih bora. Ove bore s B-osima pružanja sjever-jug i korespondirajućim pukotinskim sustavima, mogle su nastati samo pod djelovanjem regionalnog tangencijalnog stresa na pravcu istok-zapad, dakle, u laramijskoj tektonskoj fazi. Ostaci laramijskih bora sačuvali su prepoznatljivu geometriju na taj način što im je i pirenejska i neotektonska faza preborala B-osi. Promjenom nagiba osi sačuvali su se oni dijelovi laramijskih bora koji su kinematski ugrađeni u konstituciju krila dominantnih neotektonskih bora (trase osnih ravnina laramijskih bora paralelne su s neotektonskim "a-lineacijama" krila).

Pod djelovanjem pirenejske tangencijalne tektonske faze (F II) u karbonatnoj se platformi u srednjem eocenu formira fliško korito i počinje taloženje fliša (MARINČIĆ, 1981). Ovom fazom počinje dezintegracija mezozojske karbonatne platforme. Sintektonsku sedimentaciju eocen-oligocenskog fliša pod djelovanjem pirenejskog stresa na pravcu jugozapad-sjeveroistok prati podvlačenje Jadranske platforme pod Dinaride. Dinaridi se boraju tvoreći poznate strukturne fenomene obuhvaćene pojmovima "dinaridsko pružanje", "dinaridske strukture" (pružanja sjeverozapad-jugoistok) s karakterističnim jugozapadnim vergencijama.

Pirenejske su bore na području Hvara samo mjestimično sačuvane. Zbog izvorno dijagonalnog položaja prema neotektonskom stresu njihove strukturne geometrije nisu ni mogle pružiti maksimalni otpor (Sl. 2). Sačuvani su tek oni dijelovi pirenejskih bora koji su bili u kinematskom položaju da postanu konstitutivni element krila veće neotektonske bore. U tim su slučajevima zadržale i pirenejsku jugozapadnu vergenciju. Dapače, neotektonski je stres ekonomično koristio svaku zatečenu pirenejsku pukotinu koja se mogla ugraditi u njegov deformacijski sustav. Promijenila se samo kinematska funkcija starijih pukotina. Obično lijeve smične pukotine konjugiranih parova prve pirenejske h01 generacije poprimaju funkciju pukotina osne ravnine, a desne postaju tenzijske pukotine neotektonskih bora (Sl. 2).

Relativno mali broj utvrđenih relikata laramijskih i pirenejskih bora u odnosu na dominantne neotektonske bore (Sl. 3), ne umanjuje principijelno značenje njihove prisutnosti. Pod neotektonskim su stresom promijenile samo nagib B-osi, ali su zadržale osnovnu orijentaciju, pa prema tome i međusobno bitno neporemećene položaje (Sl. 4). Zato je potrebno istaknuti da je zatečeni strukturni predtež pod djelovanjem neotektonskog stresa (sjever-jug) preboran, a ne horizontalno "retrogradno rotiran" oko neotektonske c-osi, kao što se danas pokušava tumačiti svaka pojava "hvarskog pružanja" u Dinaridima (usporediti: ALJINOVIĆ et al., 1990). Uostalom, koji bi to stru-

kturni sklop mogao horizontalno rotirati osim navlake odvojene od korijena? Hvarska ljuška ili ljuške, nisu u toj situaciji. Eventualne lokalne horizontalne rotacije duž transkurentnih (h01) rasjeda su pojave na razini izdanka. Ni velika suma njihovih diferencijalnih lijevih kretanja ne doprinosi prevagi jednog smjera pomaka (rotaciji) jer ih za sličan iznos kompenziraju pomaci duž desnih transkurentnih rasjeda. Osim toga, ova kretanja spadaju u deformacije kinematskog F-stadija (četvrta h01 generacija) koji je uslijedio nakon formiranja "hvarskog pružanja". Na koncu, na plohama čela ljušaka južnih vergencija svi su tektoglifi ugrađeni perpendikularno - niti su zakrivljeni, niti sumarno pokazuju odstupanje od pravca sjever-jug.

Pojavom novog smjera globalnog stresa na pravcu sjever-jug, artikulira se neogensko-kvartarna neotektonska tangencijalna faza (F III). Podvlačenje se nastavlja i intenzivira, pa se i sama Jadranska karbonatna platforma dezintegrira na nekoliko segmenata (ALJINOVIĆ et al., 1987), dok se u Dinaridima pojavljuju strukturne deformacije pružanja istok-zapad ("hvarsko pružanje") s južnim vergencijama.

Specifični geološki razvoj i geotektonski položaj jugozapadne Istre, otoka Lastova i, vjerojatno, Visa, ukazuju da su oni relikti Jadranske karbonatne platforme. Otok Hvar je, prema tome, dio vrlo isturenog navlačnog ozemlja velike strukturne etaže Dinarida blizu zone neotektonskog podvlačenja. U toj je mjeri pretrpio i jaču kontrakciju koja se odrazila u bogatom sadržaju strukturnih deformacija neotektonske tangencijalne faze.

Mada je pravac djelovanja stresa od presudne važnosti za razumijevanje geološkog razvoja nekog područja, s kinematskog je aspekta od sekundarnog značaja. Idealni (potpuni) kinematski slijed napredovanja deformacija je identičan u bilo kojoj orijentaciji stresa pa i u neotektonskom primjeru Hvara ima vrijednosti općeg obrasca. Promjene su uvjetno označene kao A, B, C, D, E, F - stadiji kinematskog razvoja, definirano prema kriteriju progresije pojavljivanja bitnih tangencijalnih deformacijskih sustava (Sl. 5).

Prva reakcija na kompresiju je tenzija koja paralelno s ravninom glavnog i srednjeg stresa ($\sigma_1 - \sigma_2$) otvara tenzijske zjapeće pukotine kinematskog A-stadija. Ove pukotine imaju malo prostorno protezanje (centimetarskih do decimetarskih veličina) pa obično ne presjecaju ni cijelu debljinu sloja. Pored toga se dobro ističu zbog karakterističnih perastih oblika ispunjenih bijelim sparikalцитom. Značajno je da se ne pojavljuju na bilo kojem mjestu u ravnini $\sigma_1 - \sigma_2$, već samo u zonama na kojima je razlika otpornosti i tangencijalnog pritiska najmanja (h01-zona pod kutom od 45° prema pravcu glavnog stresa, modificirana za kut unutrašnjeg trenja u vapnencima iznosi cca 38°).

U kinematskom B-stadiju dolazi do kidanja h01-zone i smicanja po konjugiranom paru h01 pukotina (prva h01 generacija). Pukotine su centimetarskih do metarskih dužina, potpuno presjecaju sloj ali ne penetriraju u drugi sloj; zastaju na međuslojnom diskontinuitetu. Veličinu im zapravo kontrolira debljina sloja, pa se ne mogu razviti do kvalitete rasjeda. Često iskazuju milimetarska lijeva, odnosno desna kretanja s malim tektoglifima koji su paralelni sa slojem. Ovi mali pomaci, dakako, razmiču i tenzijske pukotine kinematskog A-stadija koje su u istoj zoni prethodile smičnim pukotinama. Nažalost, kod tih se slučajeva brka redosljed događaja, pa se ustalilo kao pra-

valo, da su smične h01 pukotine kretanjem izazvale sekundarnu pojavu tenzijskih pukotina (tada ih razlikuju kao "peraste pukotine").

A i B stadijem je glavni stres kompenziran na razini otpora što ga je pružao svaki sloj zasebno. Nastavkom djelovanja stresa, u C-stadiju, potrošeni ustroj otpora zamjenjuje krupniji sklop, skup slojeva (paket). C-stadijem opiruća masa teži homogenizaciji, okrupnjavanju, pa su od ovog stadija i sve deformacije krupnije. Opirući se materijalnoj dezintegraciji, homogeni se sklop slojeva postavlja širom frontom prema glavnom stresu. Na ovu reakciju otpora, glavni stres redistribuira sporedne stresove (σ_2 i σ_3) što je rezultiralo minimalno mogućom posljedicom - savijanjem slojeva i boranjem. Boranje je još popraćeno dodatnom kompenzacijom stresa "popuštanjem" po kompresijskom klivažu osne ravnine.

C-stadij donosi najznačajniju kontrakcijsku promjenu. Na širem planu ovaj strukturni doseg naznačava i promjenu ukupnih geoloških odnosa. Dominantan geološki proces postaje tektonski transport (na pravcu najslabijeg stresa - σ_3). Sedimentacija prestaje, odnosno nastavlja se u izmijenjenim uvjetima na nekom drugom mjestu. U kinematskom C-stadiju laramijske tektonske faze izdižu se i okopnjavaju široki prostori (ne samo karbonatne platforme), a u C-stadiju pirenejske faze mijenja se veliki sedimentacijski sustav platformskih karbonata u fliš. Neotektonskim C-stadijem, moglo bi se reći, počinje posljednje izdizanje gorja.

Napredovanjem deformiranja raste indeks stisnutosti bora, a zatim i naglašeni nagib karakteristične južne vergencije neotektonske kontrakcije. Otpor glavnom stresu još pruža duktilnost materijalne građe bora. Nadvladavanjem duktilnosti, u kinematskom D-stadiju, bore popuštaju i kidaju se po zoni na kojima je razlika otpornosti i tangencijalnog stresa najmanja - po smičnom h01 sustavu druge generacije. Suglasno velikim strukturnim formama, nastaju kilometarski h01 - sustavi reverznih rasjeda s perpendikularno ugrađenim (sjever-jug) decimetarskim do metarskim tektoglifima. Od bora se formiraju ljuške južnih vergencija kao najslikovitiji odraz neotektonske kontrakcije otoka Hvara ("hvarsko pružanje").

Ljuške su, dakle, strukturna suština otoka Hvara, a ne "otočna ljuška" kako se redovito opisuje u geološkoj literaturi. Može se pretpostaviti da je ocjeni o jednoj ljuški doprinio markantni kontakt čela najjužnije ljuške s flišom, kao i privid o relativno kontinuiranom zatvaranju naslaga integrirane jezgre s mladim naslagama. Prvo: fliš se ovdje pojavljuje samo kao najmlađi sediment i nije u funkciji suvisle podloge po kojoj se ljuška kreće. Po prirodi kinematskih uvjeta napredovanja deformiranja šireg strukturnog sklopa, može se reći jedino to da je ova najjužnija ljuška ujedno i prva pojava ljuškanja. Sjevernije od nje sljede sve mlade ljuške kinematskog D-stadija neotektonske kompresije. Drugo: ideja o jednoj ljuški podrazumijeva kinematski predstadij (C) jedne jedine goleme bore s kojom je prerađen cijeli zatečeni pirenejski strukturni sklop, kao da se i on sastojao samo od jedne goleme bore. Relikti bora ranijih, predneotektonskih faza, ukazuju da to nije točno. Neotektonski C-stadij formirao je brojne ešalonirane bore jer je morao preborati većinu zatečenih struktura starijih tektonskih faza i tek ih potom urediti u ljuške. Što je dakle uzrok prividno integralne jezgre, odnosno integralne otočne ljuške? Moglo bi se reći uporna i snažna neotektonska kompresija koja sabija i ljuška bore

do dubokog tektonskog kontakta jezgre s jezgrom i spajanja reduciranih čela bora u jedno sekundarno čelo (Sl. 6). Kinematski put od stadija do stadija ustvari je put zamjena svladanih opirućih formi s otpornijom geometrijskom gradom. Od "potrošenih" se elemenata sastavlja, integrira, velika otporna struktura koja na koncu funkcionira, a tako se i doživljava, kao jedna velika otočna ljsuska s aktualnim čelom u kontaktu s flišom.

Za kinematski E-stadij bi se moglo reći da je vjerodostojnije hvarsko svojstvo i od samog "hvarskog pružanja". Iako su širom Dinarida poznate lokalne pojave E-deformacija, one su nezaobilazni činilac ukupnog neotektonskog sklopa cijelog područja Hvara, do razine izdanka. One su zapravo puni odraz specifičnog regionalnog geotektonskog položaja otoka Hvara (kao isturenog segmenta neotektonskog navlačenja Dinarida na Jadransku platformu) ali također i odraz internog stanja strukturnog ustroja hvarskog sklopa. Naime, brojne reducirane ljsuske koje sastavljaju prividno homogenu otočnu strukturu, pod pojačanim naprežanjem počinju iskazivati autonomne odgovore na stres. Svaka se osnovna ljsuska ponaosob, od najveće do najmanje, oslobada pritiska popuštanjem po novom deformacijskom sustavu h0l pukotina i rasjeda kinematskog E-stadija. Ova se treća generacija h0l reverzних rasjeda priključuje ranijem h0l reverznom sustavu D-stadija u konjugirani h0l par. Posljedica je konjugiranje ljsusaka svih područja veličina i ukupno konjugiranje hvarske integrirane ljsuske. Južno od njezine simetralne ravnine su bore i ljsuske južne vergencije s navlačenjem prema jugu, dok se sjeverno od simetralne ravnine u E-stadiju formiraju sjeverne vergencije bora i ljsusaka prema sjeveru. Tangencijalni se stres troši na oba reverzna kretanja što udvostručuje tektonski transport na pravcu σ_3 . Tjemena struktura dolazi u položaj smanjenog bočnog pritiska, pa se šire i otvaraju stariji disjunktivni sustavi A, B i C-stadija.

Kinematski F-stadij obuhvaća najmladi sustav neotektonskih tangencijalnih deformacija otoka Hvara. Globalni je stres faktički svladao kinematsku suštinu otpora bore - ljsuske, pa se deformiranje E-sklopa nastavlja, uvjetno rečeno, slično ponavljanju B-stadija više deformacijske

razine, odnosno F-stadijem. U biti se reaktivira prva h0l generacija konjugiranih parova rasjeda B-stadija. F-stadij se pojavljuje kao četvrta h0l generacija s naglašenim horizontalnim kretanjem duž lijevih i desnih transkurentnih rasjeda koji često presjecaju sve strukturne forme hvarskog sklopa (Sl. 1). Ističu se velikim rasjedima s limoniziranim ploham i decimetarskim subhorizontalnim tektoglifima.

U kompleksnom strukturnom sklopu kao što je područje Hvara, kinematski se stadiji pojavljuju sljedom strukturne zrelosti svakog strukturnog segmenta. Zbog toga se, na planu progresije neotektonskog stresa prema jugu, od zone do zone praktički istovremeno nalaze različiti kinematski stadiji.

U ovom je prikazu zapostavljeno pitanje sudjelovanja ekstenzijskih faza i ekstenzijskih tektonskih pokreta čiji je učinak, za razliku od kontrakcijskih (tangencijalnih) faza, redovito predvidiv. Naime, one nezaobilazno sljede prestanak djelovanja svake kontrakcijske faze.

Borane naslage oslobođene tangencijalnog stresa i potpomognute širenjem prostora, sačuvanim elasticitetom teže vraćanju prema prvotnom stanju forme. Međutim, ubrzo prelaze granicu elasticiteta zbog čega se u zoni b-osi otvaraju ekstenzijske pukotine. Budući da tangencijalni stres u potpunosti smjenjuje sila gravitacije, ekstenzijske se pukotine zone b-osi aktiviraju u gravitacijski h0l sustav konjugiranih parova kliznih pukotina (Sl. 7). Po njima se, poput izostatskog kretanja, antiforme gravitacijski spuštaju, a sinformne izdižu.

Bez ove ciklične komplementarne izmjene tangencijalnih i radijalnih tektonskih pokreta, ne bi bila moguća obnova sedimentacije na istom mjestu. Faza ekstenzije poravnava izdignuto gorje i snižava erozijsku bazu do razine obnove uvjeta sedimentacije. Tako na Hvaru na aptskoj emerziji slijedi imerzija gornjeg alba, nakon emerzije alba dolazi imerzija cenomana itd.

Nova se tangencijalna faza pojavljuje tek kada brzina kretanja Afričke ploče postaje izrazito veća od brzine rotacije. Po neizbježno novom vektoru ukupnog kretanja, generira se nova kompresija globalnog stresa kao prepoznatljiva tektonska tangencijalna faza.

Manuscript received April 3, 1995.

Revised manuscript accepted April 28, 1997.

PLATE I

- Fig. 1 Relics of the Laramian fold (F I, B 180/20) in the southern limb of the central Neotectonic anticline (F III, B 270/10) of the island of Hvar; vicinity of Jelsa.
- Fig. 2 Relics of the Laramian fold (F I, B 5/10) near Vrboska.

TABLA I

- Sl. 1 Relikt laramijske bore (F I, B 180/20) u južnom krilu središnje neotektonske antiklinale (F III, B 270/10) otoka Hvara; područje Jelse.
- Sl. 2 Relikt laramijske bore (F I, B 5/10) kod Vrboske.

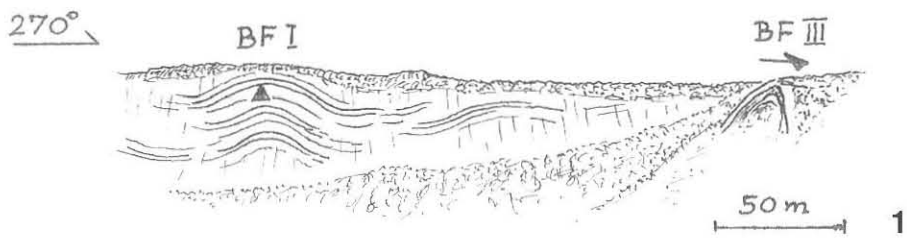
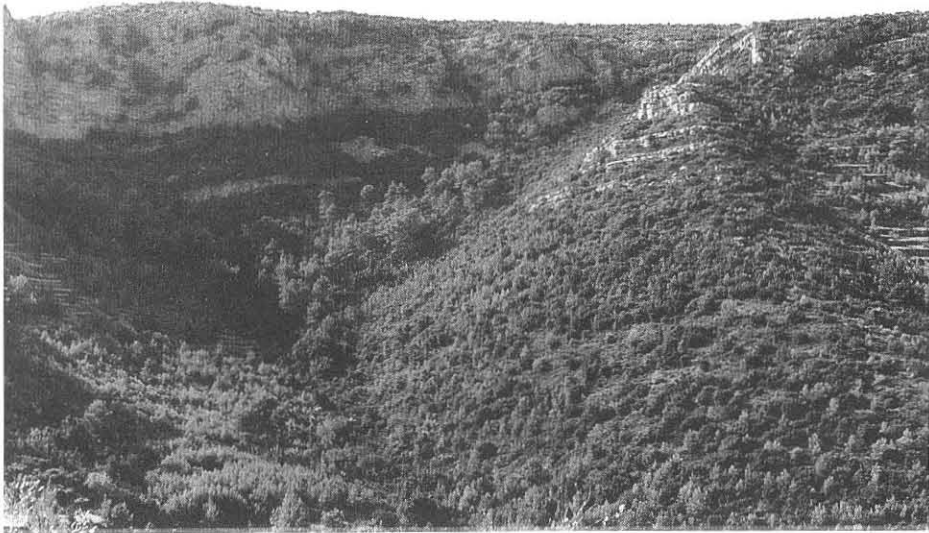

2

PLATE II

- Fig. 1 Relics of the Pyrenean fold (F II, B 297/8) with preserved south-western vergence; Vrboska.
- Fig. 2 Neotectonic fold (F III) of the northern coast of the island of Hvar with secondary northern vergence of the E stage; Mala Stiniva cove.

TABLA II

- Sl. 1 Relikt pirenejske bore (F II, B 297/8) sa sačuvanom jugozapadnom vergencijom; Vrboska.
- Sl. 2 Neotektonska (F III) bora sjeverne obale otoka Hvara sa sekundarnom sjevernom vergencijom E-stadija; uvala Mala Stiniva.

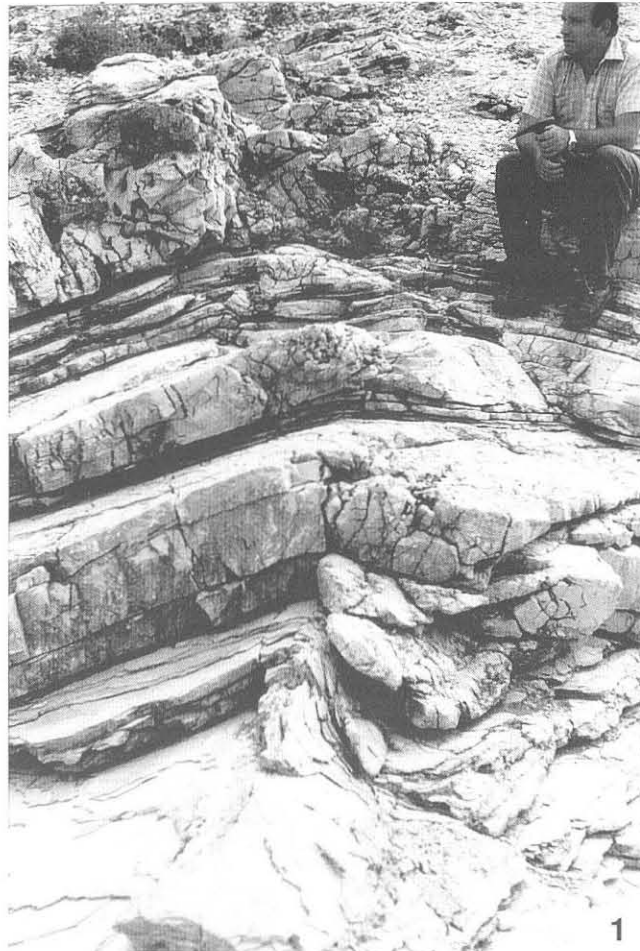

PLATE III

Figs. 1 and 2 Small-scale Neotectonic folds (F III) with the northern vergence of the E stage; Stari grad.

TABLA III

Sl. 1 i 2 Male neotektonske (F III) bore sjeverne vergencije kinematskog E-stadija; Stari grad.

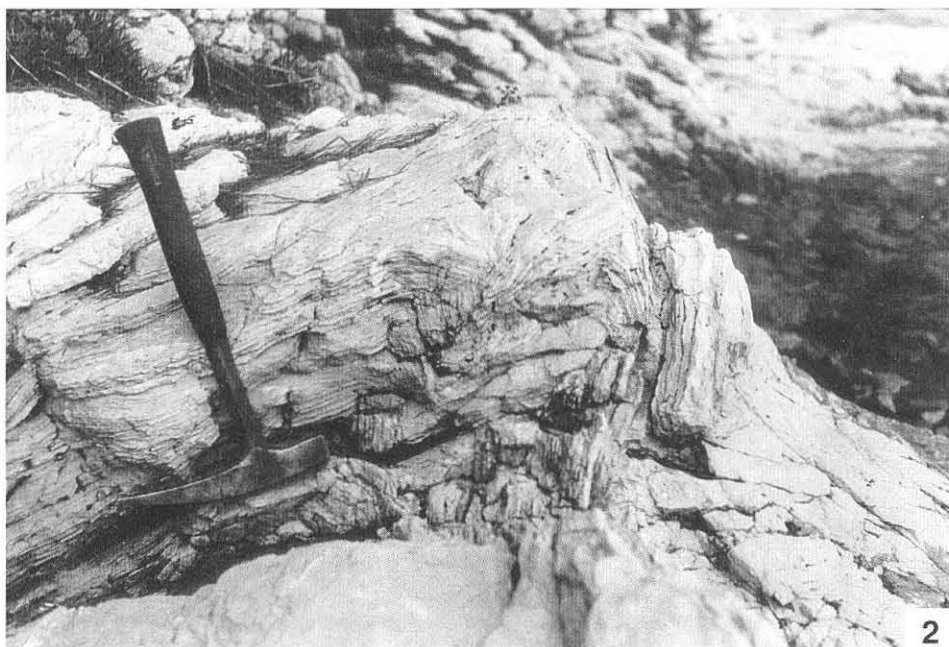
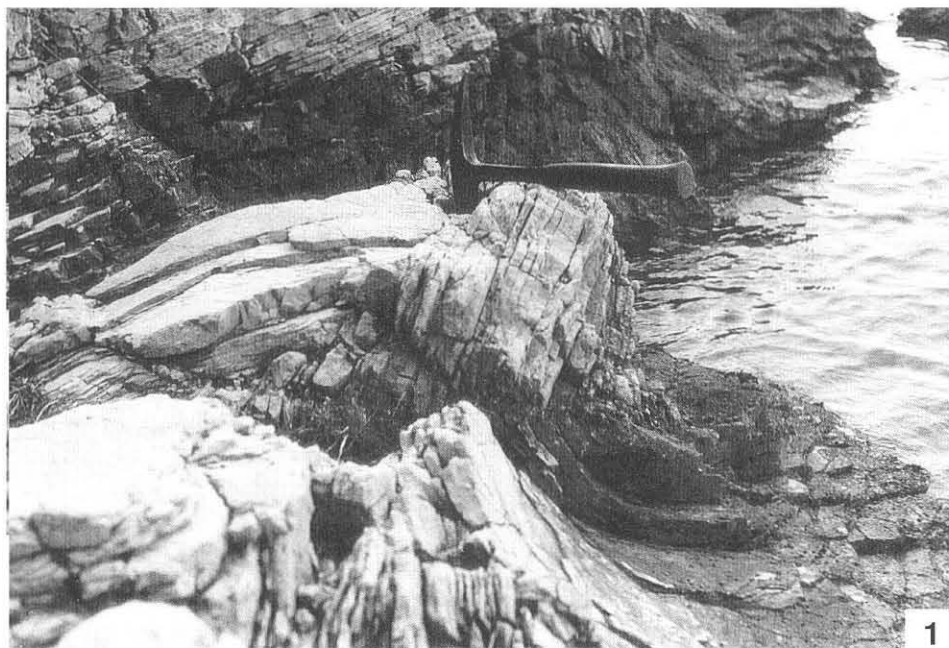

PLATE IV

Fig. 1 h01 joints of the B stage in the kinematic fabric of the fold (C stage); northern limb of the anticline in the Dubac cove.

Fig. 2 Identical kinematic stages in the core of the syncline in the Zavala cove (near Stari grad).

TABLA IV

Sl. 1 h01 pukotine B-stadija u kinematskom sklopu bore (C-stadij); sjeverno krilo antiklinale u uvali Dubac.

Sl. 2 Identično kinematsko stanje u dnu sinklinale u uvali Zavala (Starigradski zaljev).

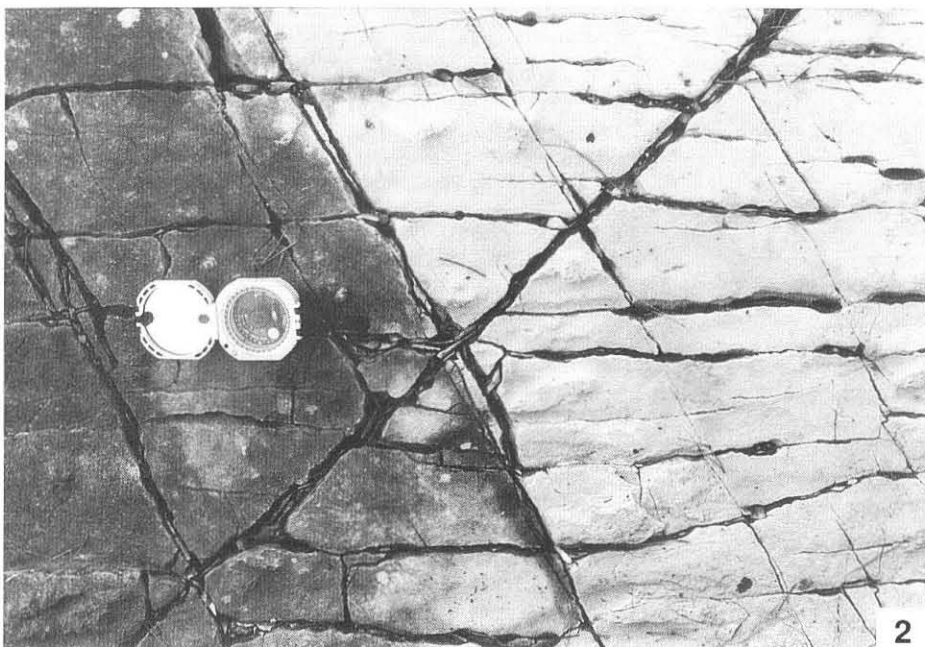

PLATE V

- Fig. 1 Conjugated h0l joints of the kinematic stage B; bedding surface near Vrboska.
- Fig. 2 Frontal part of the Neotectonic(F III) thrust-sheet of the Upper Cretaceous limestone overthrusting Palaeogene flysch. Metre-scale "a"-lineations (tectoglyphs) with movement towards the South; city of Hvar.

TABLA V

- Sl. 1 Konjugirane h0l pukotine kinematskog B-stadija; slojna ploha kod Vrboske.
- Sl. 2 Čelo neotektonske (F III) ljuske gornjokrednog vapnenca navučenog na paleogenski fliš. Metarske "a" lin-eacije (tektoglifi) s kretanjem prema jugu; grad Hvar.

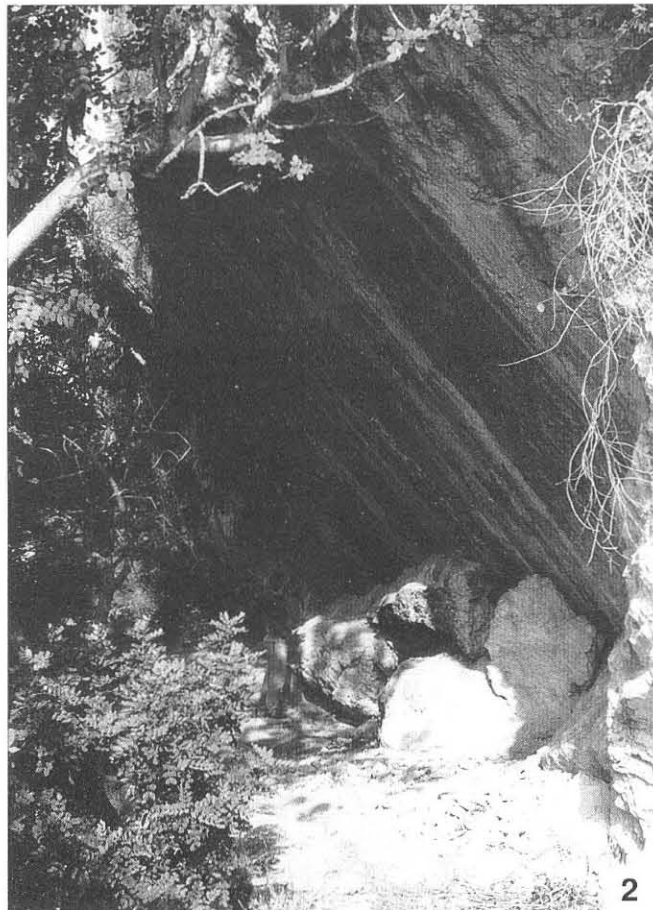

PLATE VI

Fig. 1 Tensional joints of the kinematic stage A (feather-like shaped joints) appearing in the h0l zone before h0l joints. Bedding surface in Carnian limestones in the Samoborska Gora Mt.

TABLA VI

Sl. 1 Tenzijske pukotine kinematskog A-stadija ("peraste pukotine"). Pojavljuju se u h0l zoni prije h0l pukotina; slojna ploha karničkog vapnenca Samoborske gore.

